



CAD/CAM

made in Germany



MEHR LABORINSTRUMENTE

finden Sie in unserem Labor-Gesamtkatalog

Jetzt anfordern unter +49-(0) 85 04 - 91 17 15 oder verkauf@acurata.de

More instruments for dental laboratory can be found in our complete catalogue for dental laboratory Order now at +49-(0) 85 04 - 91 17 15 or verkauf@acurata.de



acurata GmbH & Co. KG · Schulstraße 25 · 94169 Thurmansbang

Telefon +49-(0) 85 04 - 91 17 0 · Fax +49-(0) 85 04 - 91 17 90 · E-Mail info@acurata.de · www.acurata.de

5–6	NUMMERNSYSTEM CAD/CAM Numbering System
<hr/>	
7	BESCHICHTUNGSTECHNOLOGIEN Coating technology
<hr/>	
8	KOMPATIBEL ZU AMANN GIRRBACH Compatible with Amann Girrbach
<hr/>	
9–12	KOMPATIBEL ZU VHF Compatible with VHF
<hr/>	
13–14	KOMPATIBEL ZU WIELAND Compatible with Wieland
<hr/>	
15–16	KOMPATIBEL ZU ZIRKONZAHN Compatible with Zirkonzahn
<hr/>	
18–20	KOMPATIBEL ZU IMES-ICORE Compatible with imes-icore
<hr/>	
21	KOMPATIBEL ZU ROLAND Compatible with Roland
<hr/>	
22–23	KOMPATIBEL ZU SIRONA Compatible with Sirona
<hr/>	
24	KOMPATIBEL ZU YENADENT Compatible with Yenadent
<hr/>	
25–26	KOMPATIBEL ZU DCS Compatible with DCS
<hr/>	
27	KOMPATIBEL ZU DENTAL SOFTWARES CAM Compatible with Dental Softworks CAM
<hr/>	
28–38	OFFENE MASCHINENSYSTEME Open machine systems
<hr/>	
28–32	Schaft Ø: 3 mm · shank Ø: 3 mm
33–34	Schaft Ø: 4 mm · shank Ø: 4 mm
34–38	Schaft Ø: 6 mm · shank Ø: 6 mm
<hr/>	
39	HARTMETALL-FISSURENBOHRER, ANSCHLAG-/DISTANZRINGE TC-fissure bur, stop/spacer rings

HM-FRÄSER FÜR DENTALE CAD/CAM-SYSTEME

Carbide cutters for dental CAD/CAM systems

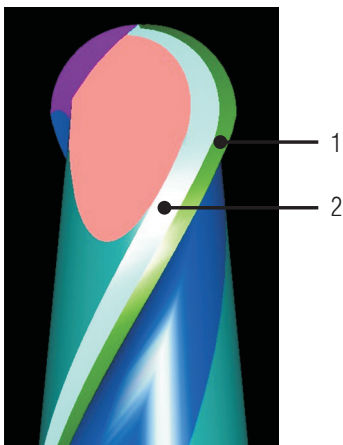

HM-Fräser zur Bearbeitung von PMMA, Wax, Composite, CoCr, PEEK, Titan und Grün-Zirkon. Schaft Ø 3 / 4 / 6 mm

Der HM-Fräser verfügt im Schneidbereich über 2 Schneiden mit doppeltem Hinterschliff (Fase 1 + 2). Das sind abgeschrägte Flächen, die den Kraftaufbau beim Schneideneintritt in den Fräswerkstoff reduzieren. Der Span reißt bei Schneidenaustritt ab; dadurch entstehen glatte Oberflächen auf dem bearbeiteten Werkstück. Die S-Ausspitzung ermöglicht ein sanftes Eintauchen in den Bearbeitungswerkstoff.

CAD/CAM-Fräser sind zum Formfräsen von Kronen- und Brücken-gerüsten aus Titan und aus Zirkonoxidkeramik im teilgesinterten Zustand (Grünling, Weißling) geeignet. Aufgrund der vielfältigen Maschinensysteme und unterschiedlichen Frässtrategien müssen die Fräsparameter, je nach System, Material und Strategie, individuell ermittelt werden, um optimale Ergebnisse zu erzielen.

Sie haben Fragen? Rufen Sie uns einfach an unter Telefon +49 (0) 85 04-91 17 68. Wir beraten Sie gerne.

TC-Cutter for working PMMA, Wax, Composite, CoCr, PEEK, titanium and green zirconium. Shank Ø 3 / 4 / 6 mm

On its cutting end, the tungsten carbide cutter possesses 2 blades with a double clearance (chamfer 1 + 2). This consists of bevelled surfaces which reduce the force accumulation during the blades' entrance into the milling material. The chip tears off when the blades exit the material; in this way, smooth surfaces are formed on the milled workpiece. The S-shaped point enables a gentle entry into the milling material. CAD/CAM cutters are suitable for form-milling crown and bridge frameworks of titanium and zirconia ceramic in the partially sintered state (green or white blanks). Due to the variety of machine systems and different milling strategies, the milling parameters must be individually determined according to system, material and strategy in order to obtain optimal results.

Do you have questions? Simply call us under phone number +49 (0) 85 04-91 17 68. We will be pleased to advise you.

NUMMERNSYSTEM CAD/CAM

Numbering system

BESTELL-BEISPIEL Ordering example

500 343 201 160 010

5	1. Stelle, first digit	Materialkennung, material designator	Hartmetall, tungsten carbide
0	2. Stelle, second digit	Beschichtungserkennung, coating code	ohne Beschichtung, without coating
0	3. Stelle, third digit	nicht belegt, not occupied	0
3	4. Stelle, fourth digit	Schaftdurchmesser in mm, shank diameter in mm	3 mm
4	5. Stelle, fifth digit	Gesamtlänge in mm, all over length in mm	43 mm
3	6. Stelle, sixth digit	+	+
2	7. Stelle, seventh digit	Formkennung Arbeitsteil AT, form classification of the working part	Radiusfräser zylindrisch, cylindric radial cutter
0	8. Stelle, eighth digit	nicht belegt, not occupied	0
1	9. Stelle, ninth digit	Anzahl der Schneiden, number of blades	1
1	10. Stelle, tenth digit	Freistellung in 1/10 mm, extra length	16,0 mm
6	11. Stelle, eleventh digit	+	+
0	12. Stelle, twelfth digit	+	+
0	13. Stelle, thirteenth digit	nicht belegt, not occupied	
1	14. Stelle, fourteenth digit	Durchmesser des Arbeitsteils in 1/10 mm, Diameter of the working part in mm	Durchmesser 1,0 mm, Diameter 1,0 mm
0	15. Stelle, fifteenth digit	+	+

WEITERES BEISPIEL: 530 648 204 120 020

Hartmetall, ac-blue Beschichtung, 6 mm Schaft-Durchmesser, 48 mm Gesamtlänge, Radiusfräser zylindrisch, 4-Schneider, Freistelllänge 12,0 mm, Arbeitsteil-Durchmesser 2,0 mm

Another example: 530 648 204 120 020

Tungsten carbide, ac-blue coating, 6 mm shank diameter, 48 mm all over length, cylindric radius cutter, 4 blades, length 12,0 mm, diameter of the working part 2,0 mm

ANSCHLAG-/DISTANZRING

500 653 202A 150 010

Für Werkzeuge aus dem UNIVERSAL-Programm. Buchstabenkennung A nach der 9. Stelle = mit Anschlagring lagernd.
Auf Kundenwunsch können alle Werkzeuge mit Anschlag-/Distanzring bei 4 mm und 6 mm Schaft-Durchmesser oder Kunststoffring bei 3 mm Schaft-Durchmesser versehen werden.

STOP/SPACER RING

500 653 202A 150 010

For tools of the universal range. The letter code A after the ninth digit = in stock with stop/spacer ring. Upon customer request, all tools can be provided with stop ring for 6 mm shank diameter or plastic ring for 3 mm shank diameter.

SYSTEM- ODER MASCHINEN-SPEZIFISCHE WERKZEUGE

500 347 202AG 170 025

Werkzeuggeometrien sowie Einspannlänge kompatibel zu Amann/Girrbach-Fräsern

SYSTEM OR MACHINE SPECIFIC TOOLS

500 347 202AG 170 025

Tool geometry as well as clamping length compatible with Amann/Girrbach-cutter

500 650 202 ZZC 020

Werkzeuggeometrien sowie Einspannlänge kompatibel zu ZirkonZahn-Fräsern

500 650 202 ZZC 020

Tool geometry as well as clamping length compatible with ZirkonZahn-cutter

MATERIALKENNUNG

5=Hartmetall

MATERIAL DESIGNATOR

5=tungsten carbide

BESCHICHTUNGSKENNUNG

0=ohne

3=ac-blue (PVD-Schicht)

4=ac-fire (PVD-Schicht nach HiPIMS)

5=ac-kristall Diamantbeschichtung (CVD-Schicht)

Coating code

0=without

3=ac-blue (PVD-coating)

4=ac-fire (PVD-coating with HiPIMS)

5=ac-crystal diamond coating (CVD-coating)

FORMKENNUNG ARBEITSTEIL

1=Fräser zylinderstumpf kantig

2=Radiusfräser zylindrisch

3=Radiusfräser konisch

4=Torusfräser zylindrisch

Form classification of the working part

1=cutter cylindric blunt-edged

2=cylindric radial cutter

3=radial cutter conical

4=cylindric torus cutter

VERSCHLEISS-SCHUTZSCHICHTEN

wear-protection coating

7



AC-BLUE

Universelle, sehr harte und glatte PVD/Verschleißschutzschicht
Schichtstärke: ca. $3,0\ \mu\text{m}$, Schichtarchitektur: nano Composite
Basis: Supernitrid $\text{AlTiN} + \text{SN}$, Schichtfarbe: blau, glänzend
Härte, HV 0,05: 3.700, Schicht ist elektrisch leitend, Max. Einsatz/Temperatur: $1.100\ ^\circ\text{C}$, Reibungskoeffizient gegen Stahl 0,2
Besonders geeignet für Trockenbearbeitung
Für alle fräsbaren Materialien, Kunststoffe, Composite, Metall und Standard Zirkonoxid

AC-BLUE

Hard and smooth PVD/ wear protection coating, coating thickness: approx. $1,5\ \mu\text{m}$, Coating architecture: nano-composite, basis: supernitride $\text{AlTiN} + \text{SN}$, Coating colour: blue, brilliant, hardness, HV 0,05: 3.700, The coating is electrically conductive, max. use/ temperature: $1.100\ ^\circ\text{C}$, Coefficient of friction against steel 0,2, particularly suitable for dry machining
For all millable materials, synthetic material, composite, metal and standard zirconium oxide



AC-FIRE

PVD Schicht nach dem HiPIMS-Verfahren, speziell für die Hartstoffzerspanung, Schichtstärke: $1,5\text{--}2,5\ \mu\text{m}$, Schichtarchitektur: Nano Composite, Basis $\text{TiAlN} + \text{Si}$, Schichtfarbe: kupferfarben, glänzend, Härte HV 0,05: 3.800, elektrisch leitend, max. Einsatztemperatur: $1.100\ ^\circ\text{C}$, Reibwert gg. Stahl 0,3; besonders geeignet für schwer zu zerspanende Legierungen – CoCr und Titan

AC-FIRE

PVD-coating on the basis of the HiPIMS-procedure, especially for the chipping of hard materials, coating thickness: approx. $1,0\ \mu\text{m}$, coating architecture: Nano composite, Basis: $\text{TiAlN} + \text{Si}$, Coating colour: copper, shiny, Hardness HV 0,05 : 3.800, electrically conductive, max. operating temperature: $1.000\ ^\circ\text{C}$, coefficient of friction against steel 0,3; particularly suitable for materials which are hard to machine – CrCo and Titanium



AC-KRISTALL (DIAMANTBESCHICHTUNG)

CVD-Spezialschicht zum Bearbeiten hoch abrasiver Materialien (z.B. ZrO), Schichtstärke: ca. $6\ \mu\text{m}$, Schichtarchitektur: nano-kristalline Schicht, Basis: Kristalline C-Schicht, Farbe: grau/schwarz, Härte: HV 0,05: 10.000, Schicht nicht elektrisch leitend, max. Einsatztemperatur: $600\text{--}700\ ^\circ\text{C}$, Standweigerung bis zu 10-fach, hohe Wärmeleitfähigkeit

AC-CRYSTAL (DIAMOND COATING)

CVD-special coating for the treatment of highly abrasive materials (e.g. ZrO), Coating thickness: approx. $6\ \mu\text{m}$, coating architecture: nano-crystalline coating, Colour: grey/ black, hardness HV 0,05: 10.000, The coating is not electrically conductive, max. operation temperature: $600\text{--}700\ ^\circ\text{C}$, Increased tool life up to factor 10, high thermal conductivity

KOMPATIBEL ZU AMANN GIRRBACH

Ceramill-Motion/Micro

Compatible with Amann Girrbach

Ceramill-Motion/Micro

ZRO, AC-KRISTALL



	550 347 202AG 170 010	550 347 202AG 170 025
Ø mm	1,0	2,5
	2-Schneider 2-blades	

Ø mm

PMMA

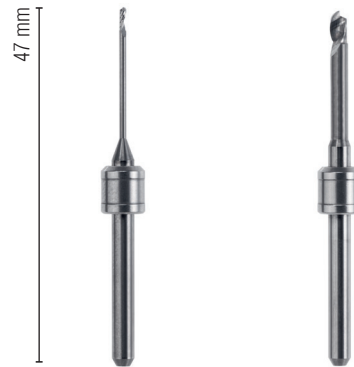

	500 347 201AG 170 010	500 347 201AG 170 025
Ø mm	1,0	2,5
	1-Schneider 1-blade	

Ø mm

UNIVERSAL



	500 347 202AG 030 003	500 347 202AG 130 006	500 347 202AG 165 010	500 347 202AG 170 025
Ø mm	0,3	0,6	1,0	2,5
	2-Schneider 2-blades			

Ø mm

UNIVERSAL (AC-BLUE)



	530 347 202AG 165 010	530 347 202AG 170 025
Ø mm	1,0	2,5
	2-Schneider 2-blades	

- Universal - Universal
- Wachs/Kunststoffe (PMMA) - wax/plastics (PMMA)
- Composites - Composites
- NEM-Werkzeuge (CoCr) - tools for non-precious alloys (CrCo)
- Zirkonoxid (ZrO) - zirconium oxide

Farben entsprechen dem Standardfarbcode der Originalwerkzeuge und unterstützen Sie bei der Auswahl.
Colours are corresponding to the standard colour code of the original tools and support you in the selection.

KOMPATIBEL ZU VHF S1 / S2 / K5 / K5+

MC-Dental smart mill unit T/W/unit, Hinrichs Dental Hinri Mill T5/5/5.8, Siladent Silamill 5/5.8/T5, Schütz Tizian Cut 5 smart/plus/dry, Goldquadrat Quattro Mill Maxi/Comfort 5X, Organical Desktop 6/7, Shera eco mill 5X-change dry, YETI digi Mill5/plus/dry

Compatible with VHF S1 / S2 / K5 / K5+

MC-Dental smart mill unit T/W/unit, Hinrichs Dental Hinri Mill T5/5/5.8, Siladent Silamill 5/5.8/T5, Schütz Tizian Cut 5 smart/plus/dry, Goldquadrat Quattro Mill Maxi/Comfort 5X, Organical Desktop 6/7, Shera eco mill 5X-change dry, YETI digi Mill5/plus/dry

UNIVERSAL ●

PMMA, COMPOSITES ●●

PMMA ●

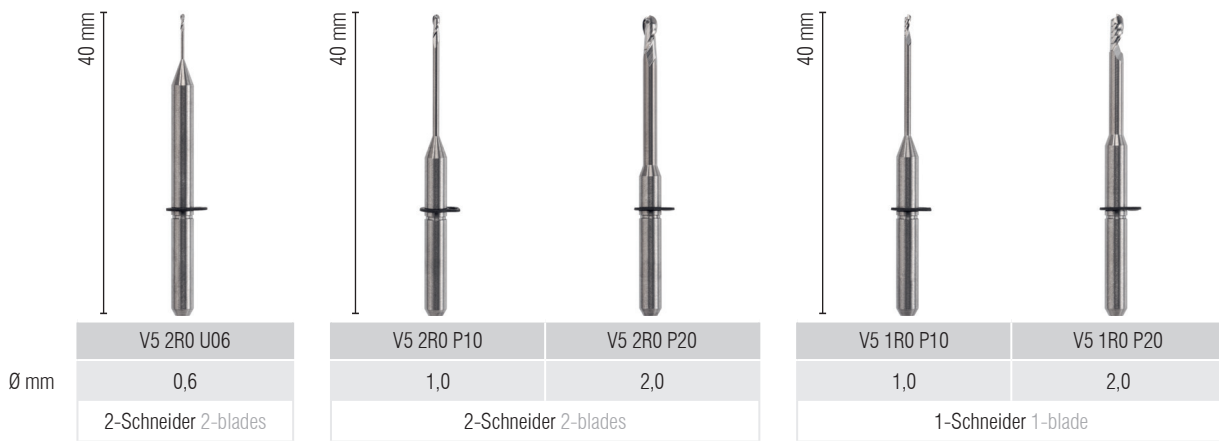

METALL (AC-FIRE) ●

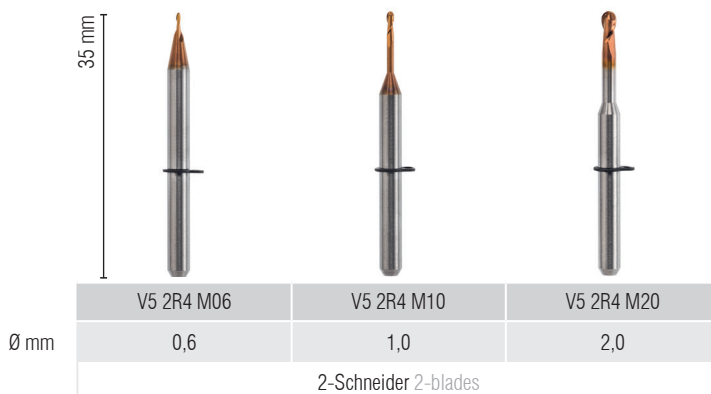

- Universal · Universal
- Composites · Composites
- Zirkonoxid (ZrO) · zirconium oxide
- Wachs/Kunststoffe (PMMA) · wax/plastics (PMMA)
- NEM-Werkzeuge (CoCr) · tools for non-precious alloys (CrCo)

Farben entsprechen dem Standardfarbcode der Originalwerkzeuge und unterstützen Sie bei der Auswahl.
Colours are corresponding to the standard colour code of the original tools and support you in the selection.

KOMPATIBEL ZU VHF S1 / S2 / K5 / K5+

MC-Dental smart mill unit T/W/unit, Hinrichs Dental Hinri Mill T5/5/5.8, Siladent Silamill 5/5.8/T5, Schütz Tizian Cut 5 smart/plus/dry, Goldquadrat Quattro Mill Maxi/Comfort 5X, Organical Desktop 6/7, Shera eco mill 5X-change dry, YETI digi Mill5/plus/dry

Compatible with VHF S1 / S2 / K5 / K5+

MC-Dental smart mill unit T/W/unit, Hinrichs Dental Hinri Mill T5/5/5.8, Siladent Silamill 5/5.8/T5, Schütz Tizian Cut 5 smart/plus/dry, Goldquadrat Quattro Mill Maxi/Comfort 5X, Organical Desktop 6/7, Shera eco mill 5X-change dry, YETI digi Mill5/plus/dry

ZRO ●

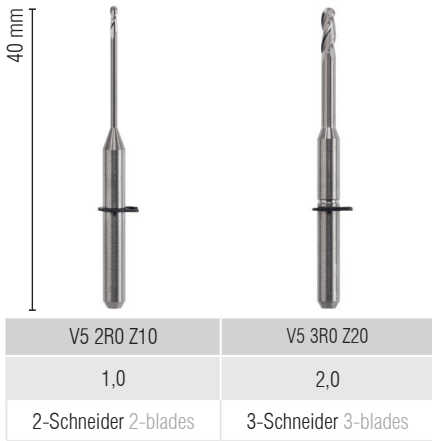

Ø mm

ZRO (AC KRISTALL) ◆ ●

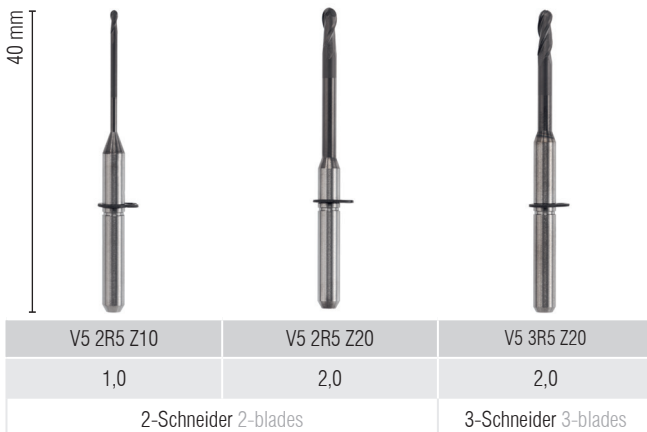

Ø mm

ZRO (AC-BLUE) ●

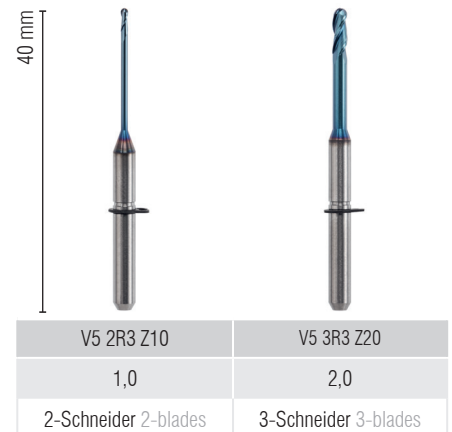

Ø mm

- Universal - Universal
- Wachs/Kunststoffe (PMMA) - wax/plastics (PMMA)
- Composites - Composites
- NEM-Werkzeuge (CoCr) - tools for non-precious alloys (CrCo)
- Zirkonoxid (ZrO) - zirconium oxide

Farben entsprechen dem Standardfarbcode der Originalwerkzeuge und unterstützen Sie bei der Auswahl.
Colours are corresponding to the standard colour code of the original tools and support you in the selection.

KOMPATIBEL ZU VHF K3 / K4

Schütz Tizian cut/plus/eco plus, Goldquadrat Quattro Mill Comfort, Mill Easy, Organical Desktop 1/3, Yeti digi Mill 4, Hindrichs Dental Hindri Mill 4, Siladent Silamill 4 edition

Compatible with VHF K3 / K4

Schütz Tizian cut/plus/eco plus, Goldquadrat Quattro Mill Comfort, Mill Easy, Organical Desktop 1/3, Yeti digi Mill 4, Hindrichs Dental Hindri Mill 4, Siladent Silamill 4 edition

UNIVERSAL ●

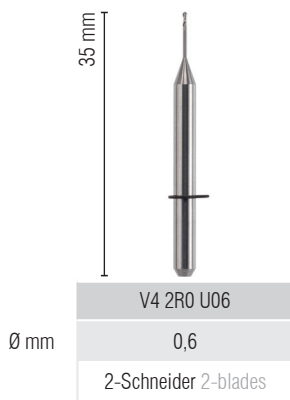

PMMA, COMPOSITES ● ●

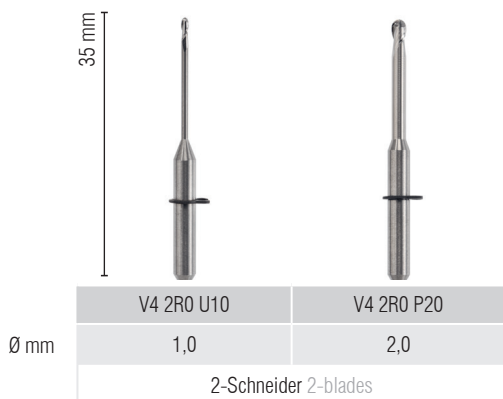

PMMA ●

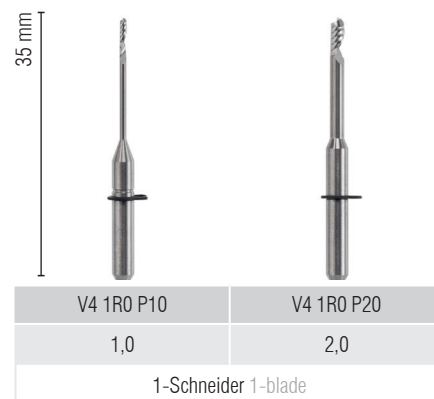

- Universal - Universal
- Wachs/Kunststoffe (PMMA) - wax/plastics (PMMA)
- Composites - Composites
- NEM-Werkzeuge (CoCr) - tools for non-precious alloys (CrCo)
- Zirkonoxid (ZrO) - zirconium oxide

Farben entsprechen dem Standardfarbcode der Originalwerkzeuge und unterstützen Sie bei der Auswahl.
Colours are corresponding to the standard colour code of the original tools and support you in the selection.

KOMPATIBEL ZU VHF K3 / K4

Schütz Tizian cut/plus/eco plus, Goldquadrat Quattro Mill Comfort, Mill Easy, Organical Desktop 1/3, Yeti digi Mill 4, Hindrichs Dental Hindri Mill 4, Siladent Silamill 4 edition

Compatible with VHF K3/K4

Schütz Tizian cut/plus/eco plus, Goldquadrat Quattro Mill Comfort, Mill Easy, Organical Desktop 1/3, Yeti digi Mill 4, Hindrichs Dental Hindri Mill 4, Siladent Silamill 4 edition

METALL (AC-FIRE) ●

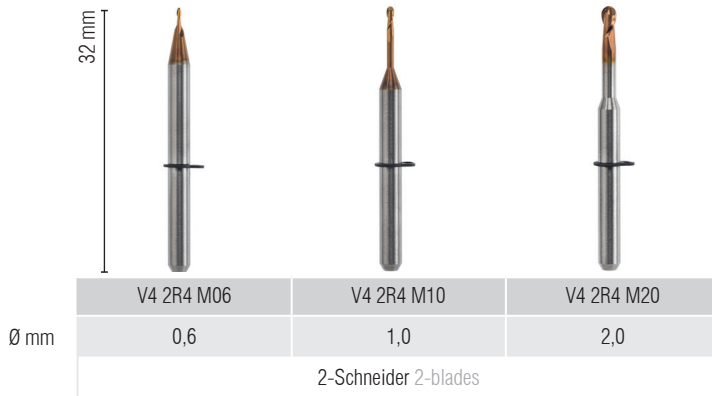

ZRO ●

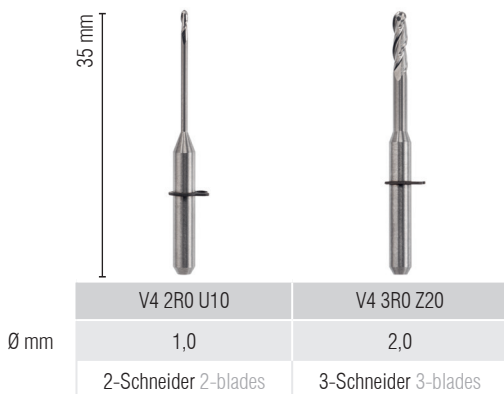

ZRO (AC-BLUE) ●

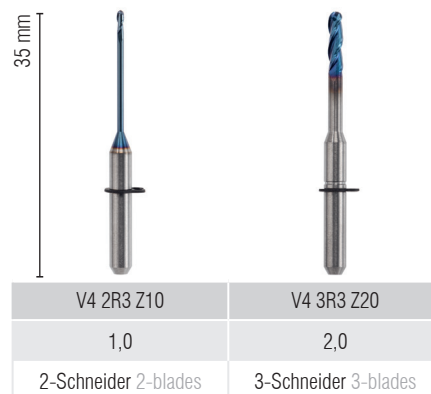

KOMPATIBEL ZU WIELAND

ZENOTEC-select/SELECT ion

Compatible with Wieland
ZENOTEC-SELECT/SELECT ion

UNIVERSAL BASIS

PMMA / WACHS SPEZIAL-S

Ø mm						
	W5 2R0 U07	W5 2R0 U10	W5 2R0 U25	W5 1R0 U07	W5 1R0 U10	W5 1R0 U25
	0,7	1,0	2,5	0,7	1,0	2,5
	2-Schneider 2-blades			1-Schneider 1-blade		

COCR / TITAN SPEZIAL-N (AC-FIRE)

UNIVERSAL (AC-BLUE)

ZRO PREMIUM-P (AC-KRISTALL)

Ø mm							
	W5 2R4 M06	W5 2R4 M10	W5 2R4 M20	W5 2R3 U10	W5 2R3 U25	W5 2R5 U10	W5 2R5 U25
	0,6	1,0	2,0	1,0	2,5	1,0	2,5
	2-Schneider 2-blades						

KOMPATIBEL ZU WIELAND

ZENOTEC mini

Compatible with Wieland

ZENOTEC mini



UNIVERSAL BASIS

35 mm

	W4 2R0 U07	W4 2R0 U10	W4 2R0 U25
Ø mm	0,7	1,0	2,5
	2-Schneider 2-blades		

PMMA / WACHS SPEZIAL-S

35 mm

	W4 1R0 U07	W4 1R0 U10	W4 1R0 U25
	0,7	1,0	2,5
	1-Schneider 1-blade		

COCR / TITAN SPEZIAL-N (AC-FIRE)

32 mm

	W4 2R4 M06	W4 2R4 M10	W4 2R4 M20
Ø mm	0,6	1,0	2,0
	2-Schneider 2-blades		

UNIVERSAL BASIS (AC-BLUE)

35 mm

	W4 2R3 U10	W4 2R3 U25
	1,0	2,5
	2-Schneider 2-blades	

- Sintermetall - sintered metal
- Kunststoffe (PMMA) - plastics (PMMA)
- Zirkonoxid (ZrO) - zirconium oxide

- Titan - titanium
- Wachs - wax
- NEM-Werkzeuge (CoCr) - tools for non-precious alloys (CrCo)

Farben entsprechen dem Standardfarbcode der Originalwerkzeuge und unterstützen Sie bei der Auswahl.
Colours are corresponding to the standard colour code of the original tools and support you in the selection.

KOMPATIBEL ZU ZIRKONZAHN

3 mm Schaft

Compatible with Zirkonzahn

3 mm shank

ZRO (AC-KRISTALL) ○



	550 357 202 ZZ 010	550 357 202 ZZ 020
Ø mm	1,0	2,0
	2-Schneider 2-blades	

PMMA PREMIUM

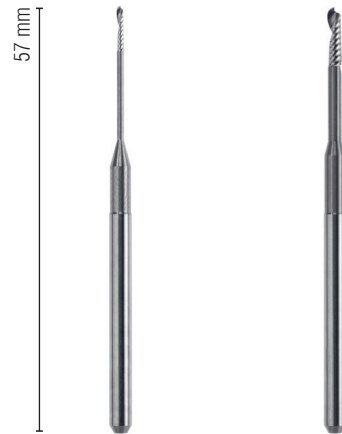

	500 357 201 ZZ 010	500 357 201 ZZ 020
	1,0	2,0
	1-Schneider 1-blade	

UNIVERSAL ○



	500 357 202 ZZ 005	500 357 202 ZZ 010	500 357 202 ZZ 020
Ø mm	0,5	1,0	2,0
	2-Schneider 2-blades		

UNIVERSAL (AC-BLUE) ○



	530 357 202 ZZ 010	530 357 202 ZZ 020
	1,0	2,0
	2-Schneider 2-blades	

- Sintermetall · sintered metal
- Kunststoffe (PMMA) · plastics (PMMA)
- Zirkonoxid (ZrO) · zirconium oxide

- Titan · titanium
- Wachs · wax
- NEM-Werkzeuge (CoCr) · tools for non-precious alloys (CrCo)

Farben entsprechen dem Standardfarbcode der Originalwerkzeuge und unterstützen Sie bei der Auswahl.
Colours are corresponding to the standard colour code of the original tools and support you in the selection.

KOMPATIBEL ZU ZIRKONZAHN

6 mm Schaft

Compatible with the Zirkonzahn

6 mm shank

UNIVERSAL ○ ● ● ●

500 650 202 ZZ 005	500 650 202 ZZ 010	500 650 202 ZZ 020
0,5	1,0	2,0
2-Schneider 2-blades		

PMMA PREMIUM ● ●

500 650 202 ZPP 010	500 650 201 ZPP 020
1,0	2,0
2-Schneider 2-blades	1-Schneider 1-blade

TITAN, COCR ○ ●

500 650 102 ZZC 005	500 650 202 ZZC 010	500 650 202 ZZC 020	500 650 202 ZZC 030	500 650 404 ZZC 015	500 650 404 ZZC 020	500 650 404 ZZC 030
0,5	1,0	2,0	3,0	1,5	2,0	3,0
2-Schneider 2-blades				4-Schneider 4-blades		
□	○	○	○	□	□	□
flach flat	rund round			torus torus		

VHF imes-icore CORiTEC

Dental Concept Systems

Shera eco mill Schütz Tizian

Goldquadrat Quattro Mill Organical

Desktop Zirkonzahn Shera eco

mill Yeti digi Mill5 Sirona

Roland Wieland Yenadent

Amann Girrbach



Instrumente bequem 24 Stunden online einkaufen

www.acurata-cadcam.de



HM-FRÄSER FÜR DENTALE CAD/CAM-SYSTEME

Mit unserem großen Produktspektrum im Bereich dentaler CAD/CAM Werkzeuge, haben wir sicherlich auch für Ihre Anwendung die passenden Fräser im Programm. Zudem können wir alle marktüblichen CAD/CAM-Systeme bedienen. Außerdem bieten wir viele unserer Werkzeuge mit Hochleistungsbeschichtungen an. Je nach Anwendungsgebiet kann dadurch die Standzeit der Werkzeuge noch einmal gesteigert werden.

Als OEM-Lieferant nationaler wie internationaler Werkzeug- und Maschinenhersteller vertrauen viele namhafte Firmen auf unser Knowhow. Das komplette Sortiment finden Sie online. Sie haben Fragen?

Rufen Sie einfach an unter +49 (0) 85 04-9117-68 oder schreiben Sie uns an cadcam@acurata.de Wir beraten Sie gerne!

KOMPATIBEL ZU IMES-ICORE

CORiTEC 140i–250i 3 mm Schaft

Compatible with imes-icore

CORiTEC 140i–250i 3 mm shank



Weitere Fräser für alternative Dentalsoftworks CAM-Software auf Seite 27.

More cutters for alternative CAM-software Dentalsoftworks on page 27.

ZRO, PMMA

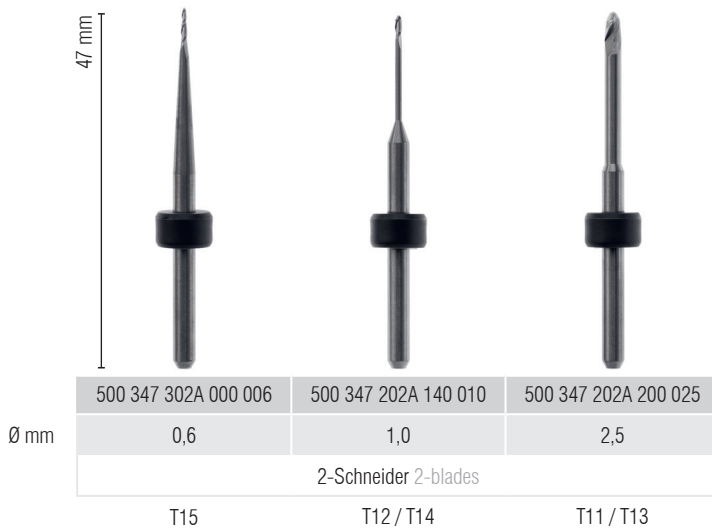

ZRO (AC-KRISTALL)

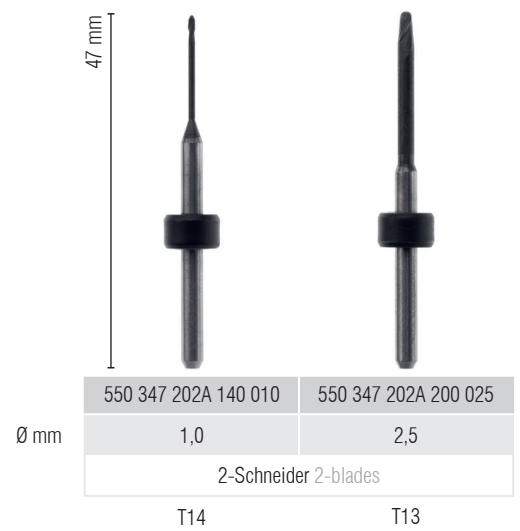

COCR, TITAN (AC-FIRE)

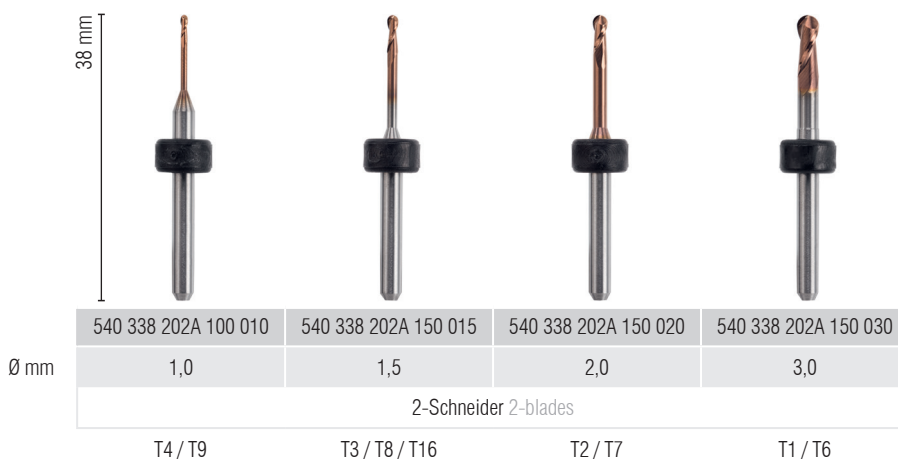

PMMA, WAX

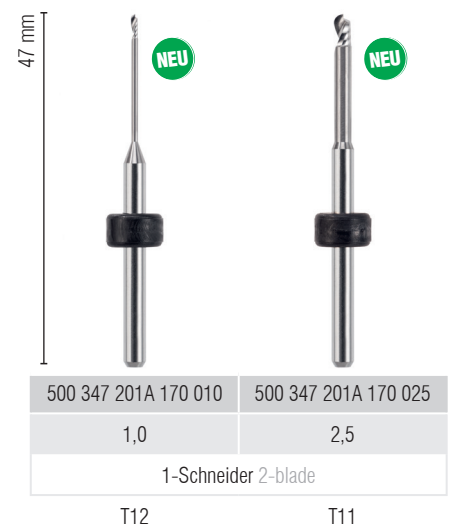

KOMPATIBEL ZU IMES-ICORE

CORiTEC 350i–750i 6 mm Schaft

Compatible with imes-icore

CORiTEC 350i–750i 6 mm shank



Weitere Fräser für alternative Dentalsoftworks CAM-Software auf Seite 27.

More cutters for alternative CAM-software Dentalsoftworks on page 27.

ZRO, PMMA

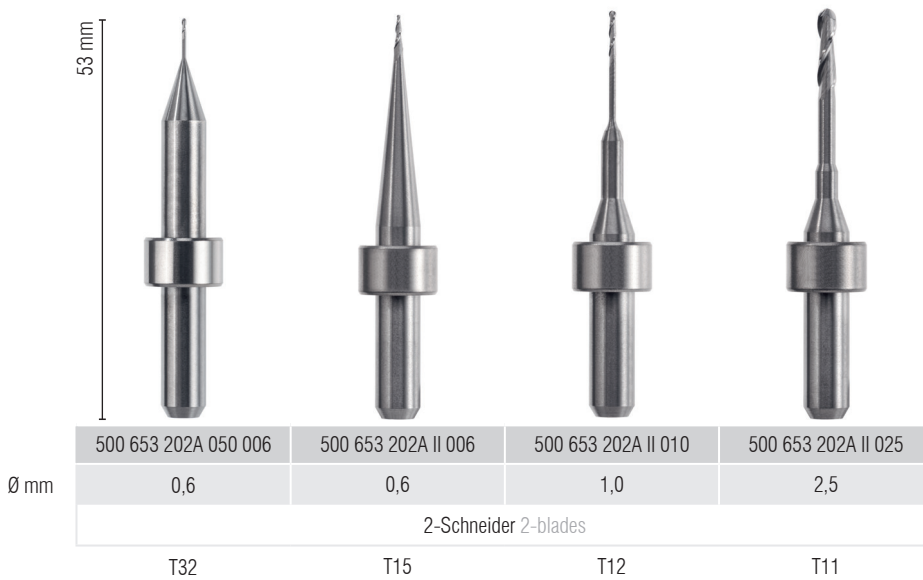

ZRO (AC-KRISTALL)

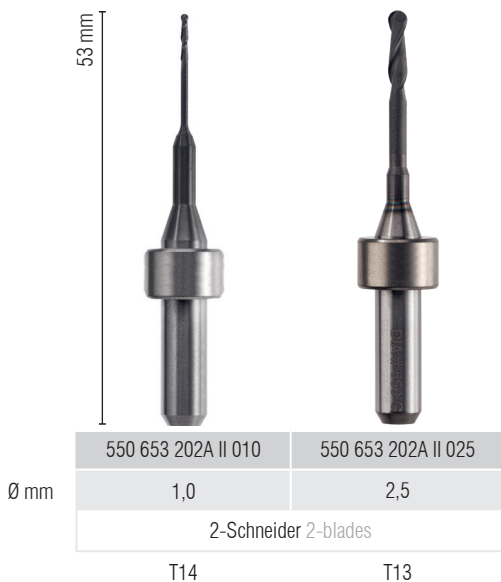

PMMA, WAX

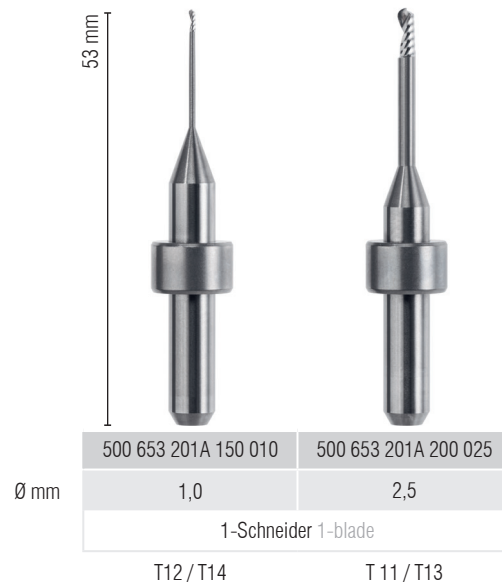

KOMPATIBEL ZU IMES-ICORE

CORiTEC 350i – 750i 6 mm Schaft

Compatible with imes-icore

CORiTEC 350i – 750i 6 mm shank



Weitere Fräser für alternative Dentalsoftworks CAM-Software auf Seite 27.

More cutters for alternative CAM-software Dentalsoftworks on page 27.

UNIVERSAL (AC-FIRE)



540 653 102A 150 015
Ø mm 1,5
2-Schneider 2-blades

T81



COCR, TITAN (AC-FIRE)

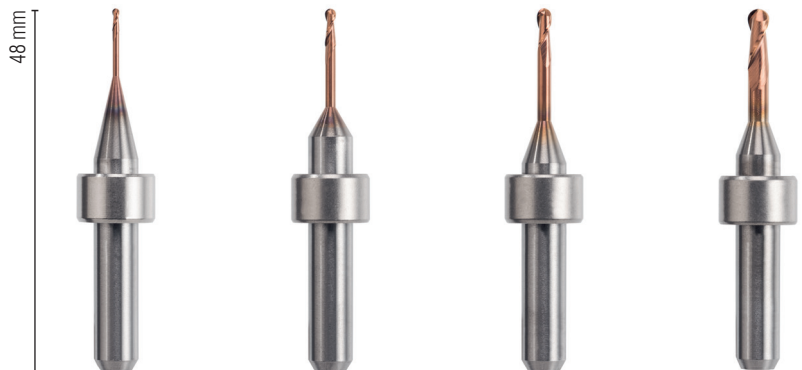

540 648 202A 085 010	540 648 202A 130 015	540 648 202A 120 020	540 648 202A 150 030
1,0	1,5	2,0	3,0
2-Schneider 2-blades			

T4 / T9

T3 / T8

T2 / T7

T1 / T6

COCR (AC-FIRE)

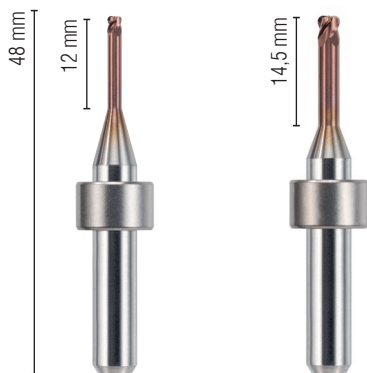

540 648 414A 120 020	540 648 414A 145 030
Ø mm 2,0	3,0
4-Schneider 4-blades	

Kantenradius 0,6 mm
edge radius 0,6 mm

Kantenradius 0,8 mm
edge radius 0,8 mm

TITAN (AC-BLUE)

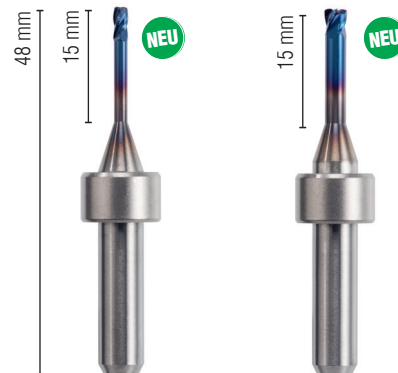

530 648 404A 150 020	530 648 404A 150 030
Ø mm 2,0	3,0
4-Schneider 4-blades	

Kantenradius 0,15 mm
edge radius 0,15 mm

Kantenradius 0,25 mm
edge radius 0,25 mm

Doppelradius double radius

KOMPATIBEL ZU ROLAND

DWX -4 -50 -51D -52DC

Compatible with Roland

DWX -4 -50 -51D -52DC

UNIVERSAL

	500 448 202 100 006	500 448 202 150 008	500 448 202 150 010	500 448 202 150 020	500 448 202 200 020
Ø mm	0,6	0,8	1,0	2,0	2,0
	2-Schneider 2-blades				

PMMA

	500 448 201 150 010	500 448 201 200 020
Ø mm	1,0	2,0
	1-Schneider 1-blade	

ZRO (AC-KRISTALL)

	550 448 202 150 010	550 448 202 200 020
Ø mm	1,0	2,0
	2-Schneider 2-blades	

KOMPATIBEL ZU SIRONA

MC X5, 3 mm Schaft

Compatible with Sirona

MC X5, 3 mm shank

ZRO



500 342 202 SD1 005	500 343 202 SD1 010	500 344 204 SD1 025
0,5	1,0	2,5
2-Schneider 2-blades		4-Schneider 4-blade

Ø mm

ZRO (AC-KRISTALL)



550 342 202 SD1 005	550 343 202 SD1 010	550 344 204 SD1 025
0,5	1,0	2,5
2-Schneider 2-blades		4-Schneider 4-blade

PMMA



500 342 202 SD2 005	500 343 202 SD2 010	500 344 202 SD2 025
0,5	1,0	2,5
2-Schneider 2-blades		

Ø mm

KOMPATIBEL ZU SIRONA

MC X5, 3 mm Schaft

Compatible with Sirona

MC X5, 3 mm shank

COMPOSITE (AC-BLUE)

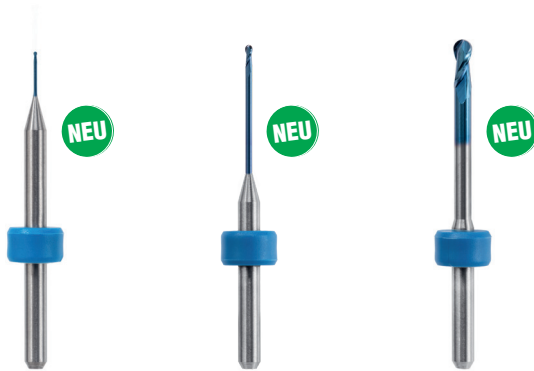

	530 342 202 SD3 005	530 343 202 SD3 010	530 344 202 SD3 025
Ø mm	0,5	1,0	2,5
	2-Schneider 2-blades		

TITAN (AC-FIRE)



	540 338 202 SD4 010	540 338 202 SD4 020
	1,0	2,0
	2-Schneider 2-blades	

DIAMANTSCHLEIFER Ausschließlich für Nassbearbeitung von Glas- und Hybridkeramiken

Diamond grinder exclusively for wet processing of glass- and hybrid ceramics



	806 335 400 054 014	806 336 300 054 012	806 337 400 076 022
Ø mm	1,4	1,2	2,2
	Diamantschleifer diamond grinder		

KOMPATIBEL ZU YENADENT

4 mm Schaft

Compatible with Yenadent

4 mm shank

ZRO (AC-KRISTALL)

ZRO, PMMA

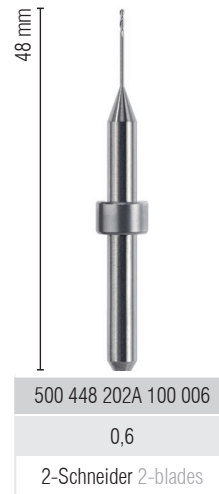
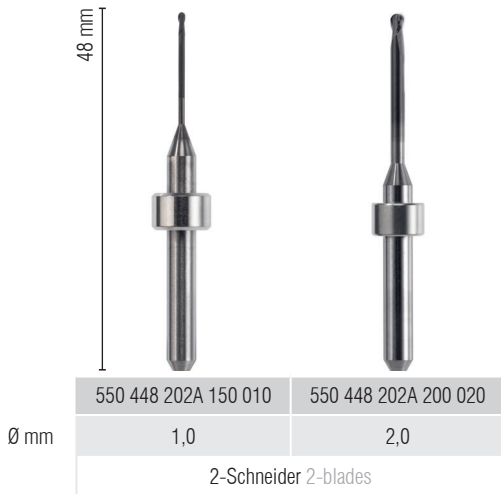

PMMA

COCR, TITAN (AC-FIRE)

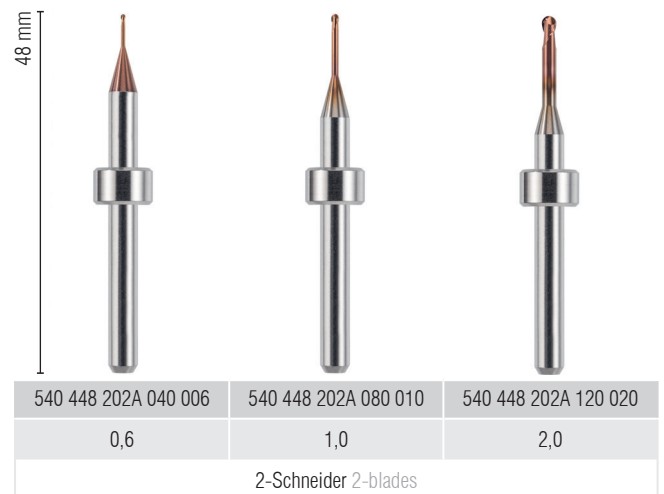
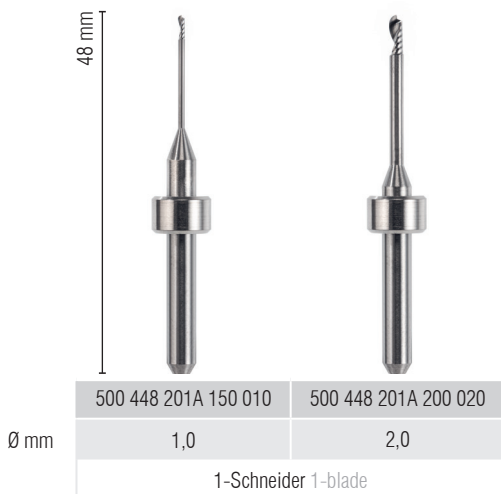

KOMPATIBEL ZU DCS

6 mm Schaft

25 DCS

Compatible with DCS

6 mm shank

ZRO, PEEK, PMMA, WAX

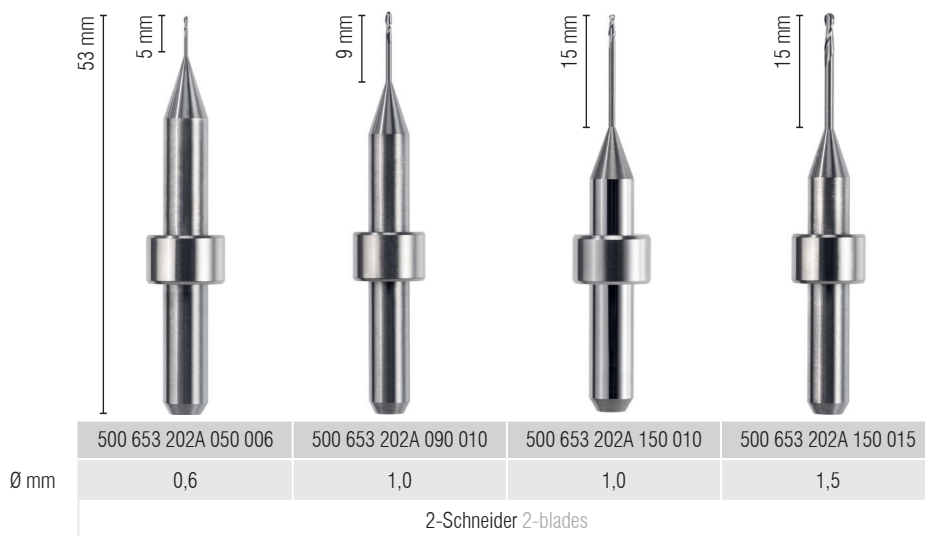

ZRO, PEEK, PMMA, WAX

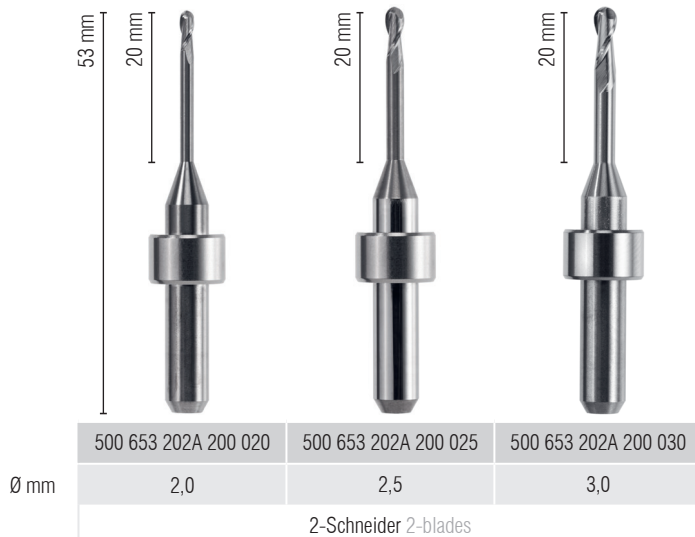

ZRO, PEEK, PMMA, WAX (AC-BLUE)

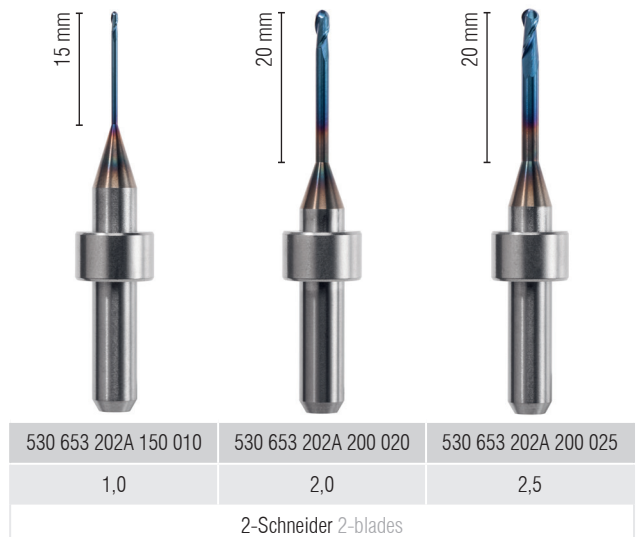

KOMPATIBEL ZU DCS

6 mm Schaft

Compatible with DCS

6 mm shank

PMMA

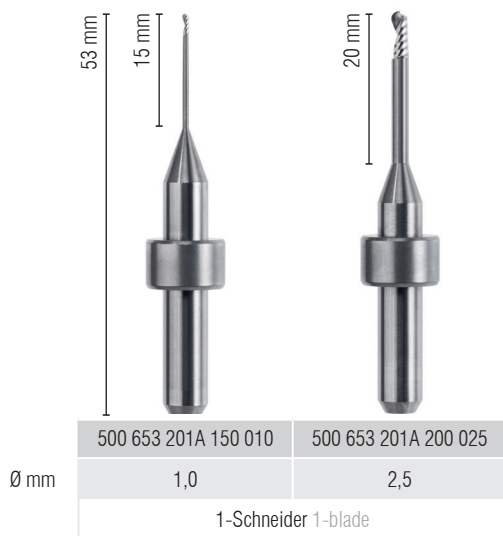

ZRO (AC-KRISTALL)

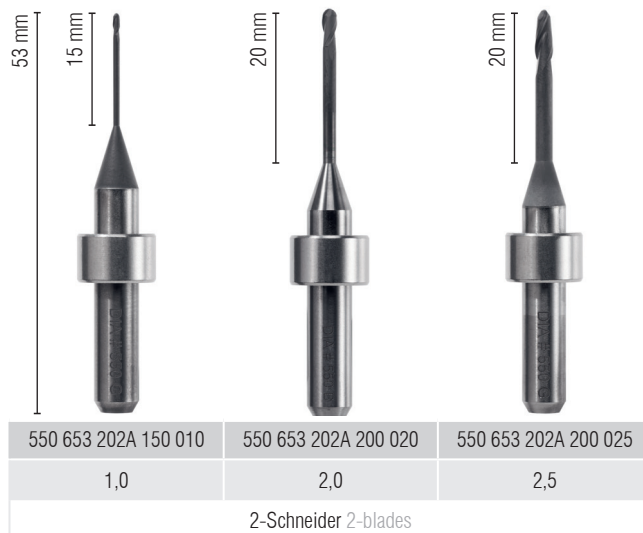

KOMPATIBEL ZU DENTAL SOFTWORKS CAM

Compatible with Dentalsoftworks CAM

PMMA, WAX

500 653 202 200 010	500 653 202A 200 010	500 653 201 200 020	500 653 201A 200 020	500 653 201 250 020	500 653 201A 250 020
1,0	1,0	2,0	2,0	2,0	2,0
2-Schneider 2-blades		1-Schneider 1-blade			

COCR, TITAN (AC-FIRE)

PMMA, WAX

ZRO (AC-KRISTALL)

540 648 403 140 020	540 648 403A 140 020	500 347 202A 130 006	500 347 202A 170 010	500 347 201A 200 020	550 347 202A 170 010	550 347 202A 200 020
2,0	2,0	0,6	1,0	2,0	1,0	2,0
3-Schneider 3-blades		2-Schneider 2-blades		1-Schneider 1-blade	2-Schneider 2-blades	

Doppelradius double radius

Kantenradius 0,3 mm edge radius 0,3 mm

OFFENE MASCHINENSYSTEME

Ergänzungsprogramm

Open systems

Supplementary program

338-SERIE Schaft Ø: 3 mm, Länge: 38 mm

shank Ø: 3 mm, lenght: 38 mm



	500 338 302 000 008	500 338 202 100 010	500 338 202 150 010
Ø mm	0,8	1,0	1,0
	2-Schneider 2-blades		



	500 338 202 150 015	500 338 202 150 020	500 338 202 150 030
Ø mm	1,5	2,0	3,0
	2-Schneider 2-blades		

OFFENE MASCHINENSYSTEME

Ergänzungsprogramm

Open systems
Supplementary program

343-SERIE Schaft Ø: 3 mm, Länge: 43 mm

shank Ø: 3 mm, length: 43 mm

	43 mm	18 mm	15 mm	18 mm	20 mm
	10 mm				
	500 343 202 100 007	500 343 202 180 007	500 343 202 150 010	500 343 202 180 010	500 343 202 200 010
Ø mm	0,7	0,7	1,0	1,0	1,0
	2-Schneider 2-blades				

	43 mm	27 mm	15 mm	20 mm	15 mm	20 mm
	20 mm					
	500 343 202 200 020	500 343 202 270 020	500 343 202 150 025	500 343 202 200 025	500 343 202 150 030	500 343 202 200 030
Ø mm	2,0	2,0	2,5	2,5	3,0	3,0
	2-Schneider 2-blades					

OFFENE MASCHINENSYSTEME

Ergänzungsprogramm

Open systems

Supplementary program

343-SERIE Schaft Ø: 3 mm, Länge: 43 mm

shank Ø: 3 mm, length: 43 mm

AC-BLUE

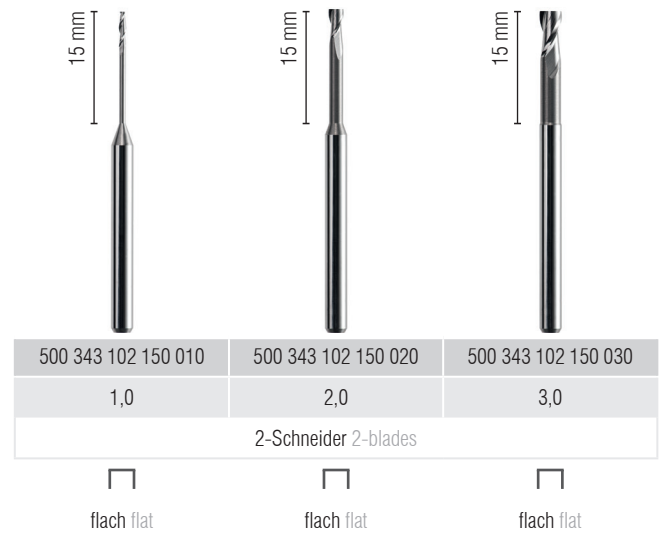
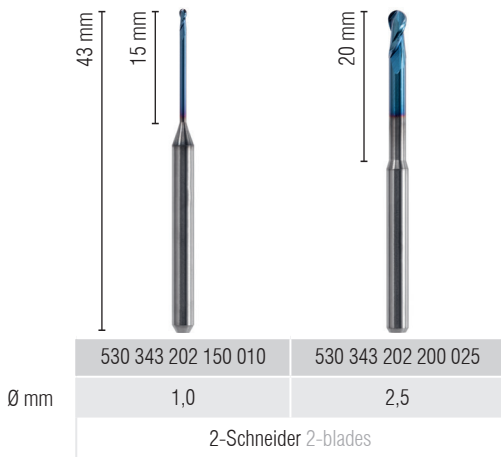

ZRO (AC-KRISTALL)

Schaft Ø: 3 mm, Länge: 43 mm

shank Ø: 3 mm, length: 43 mm

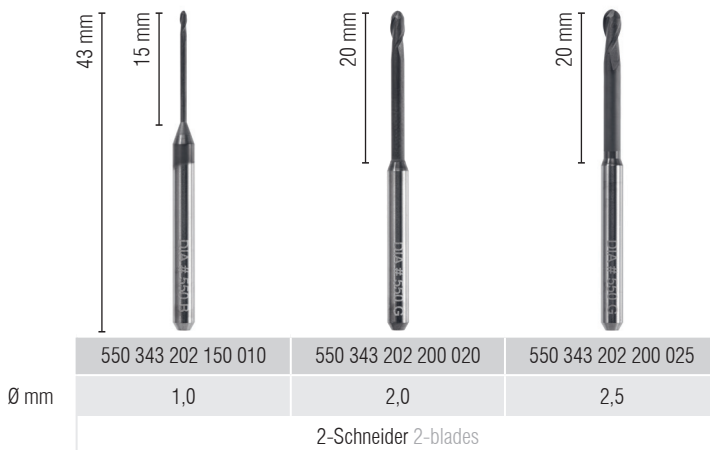

OFFENE MASCHINENSYSTEME

Ergänzungsprogramm

Open systems
Supplementary program

	500 343 201 160 010	500 343 201 200 020	500 343 201 200 025	500 343 201 120 030
Ø mm	1,0	2,0	2,5	3,0
	1-Schneider 1-blade			

347-SERIE Schaft Ø: 3 mm, Länge: 47 mm

shank Ø: 3 mm, length: 47 mm

	500 347 202 130 006	500 347 202 170 010	500 347 202 180 010	500 347 202 200 020	500 347 202 170 025
Ø mm	0,6	1,0	1,0	2,0	2,5
	2-Schneider 2-blades				

OFFENE MASCHINENSYSTEME

Ergänzungsprogramm

Open systems

Supplementary program

347-SERIE Schaft Ø: 3 mm, Länge: 47 mm

shank Ø: 3 mm, length: 47 mm



ZRO (AC-KRISTALL) 

Schaft Ø: 3 mm, Länge: 47 mm

shank Ø: 3 mm, length: 47 mm

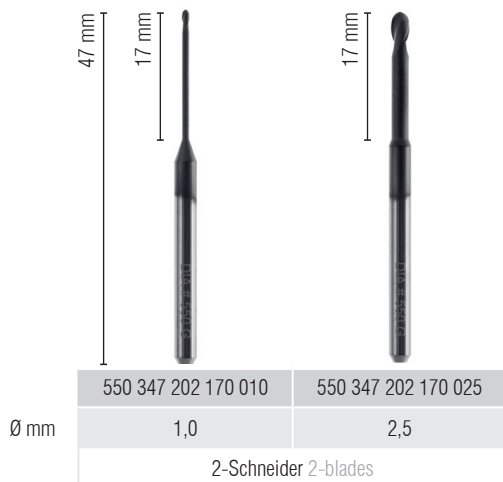

350-SERIE

Schaft Ø: 3 mm, Länge: 50 mm – extralang

shank Ø: 3 mm, length: 50 mm – extra long

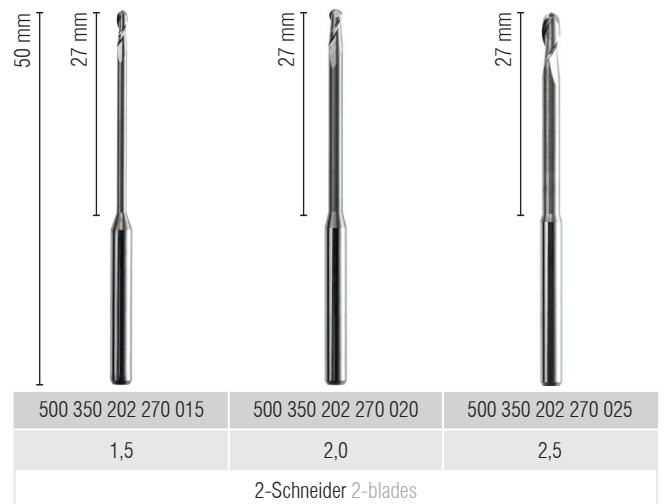





OFFENE MASCHINENSYSTEME

Ergänzungsprogramm

Open systems
Supplementary program

448-SERIE Schaft Ø: 4 mm, Länge: 48 mm

shank Ø: 4 mm, length: 48 mm

					
	500 448 202 100 006	500 448 202 080 008	500 448 202 150 008	500 448 202 090 010	500 448 202 150 010
Ø mm	0,6	0,8	0,8	1,0	1,0
	2-Schneider 2-blades				

					
	500 448 202 150 020	500 448 202 200 020	500 448 202 150 030	500 448 201 150 010	500 448 201 200 020
Ø mm	2,0	2,0	3,0	1,0	2,0
	2-Schneider 2-blades			1-Schneider 1-blade	

OFFENE MASCHINENSYSTEME

Ergänzungsprogramm

Open systems

Supplementary program

448-SERIE Schaft Ø: 4 mm, Länge: 48 mm

shank Ø: 4 mm, length: 48 mm

AC-BLUE



530 448 204 120 020	530 448 204 150 030
2,0	3,0
4-Schneider 4-blades	

Ø mm

ZRO (AC-KRISTALL)



550 448 202 150 010	550 448 202 200 020	550 448 202 250 020
1,0	2,0	2,0
2-Schneider 2-blades		

648-SERIE Schaft Ø: 6 mm, Länge: 48 mm

shank Ø: 6 mm, length: 48 mm

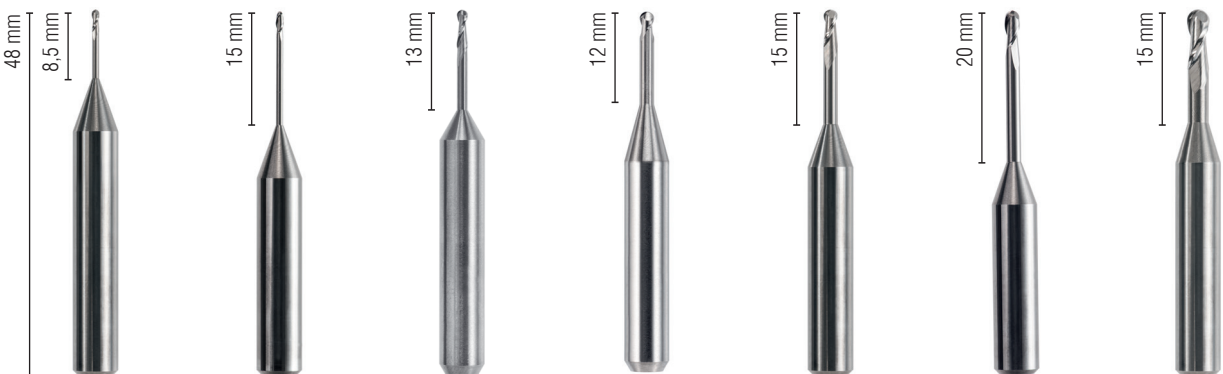

500 648 202 085 010	500 648 202 150 010	500 648 202 130 015	500 648 202 120 020	500 648 202 150 020	500 648 202 200 020	500 648 202 150 030
1,0	1,0	1,5	2,0	2,0	2,0	3,0
2-Schneider 2-blades						

Ø mm

OFFENE MASCHINENSYSTEME

Ergänzungsprogramm

Open systems
Supplementary program

648-SERIE Schaft Ø: 6 mm, Länge: 48 mm

shank Ø: 6 mm, length: 48 mm

AC-FIRE



500 648 204 120 020
Ø mm 2,0
4-Schneider 4-blades



500 648 414 120 020	500 648 414 145 030
2,0	3,0
4-Schneider 4-blades	



Kantenradius 0,6 mm
edge radius 0,6 mm

Kantenradius 0,8 mm
edge radius 0,8 mm



540 648 414 120 020	540 648 414 145 030
2,0	3,0
4-Schneider 4-blades	



Kantenradius 0,6 mm
edge radius 0,6 mm

Kantenradius 0,8 mm
edge radius 0,8 mm



AC-FIRE



540 648 403 140 020
Ø mm 2,0
3-Schneider 3-blades

Kantenradius 0,3 mm
edge radius 0,3 mm

Doppelradius
double radius

AC-BLUE

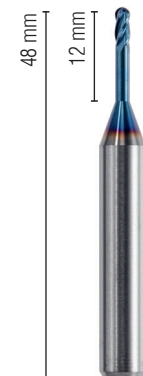

530 648 204 120 020	530 648 204 150 030	530 648 404 150 020	530 648 404 150 030
2,0	3,0	2,0	3,0
4-Schneider 4-blades			



Kantenradius 0,15 mm
edge radius 0,15 mm

Doppelradius
double radius



Kantenradius 0,25 mm
edge radius 0,25 mm

OFFENE MASCHINENSYSTEME

Ergänzungsprogramm

Open systems
Supplementary program

653-SERIE Schaft Ø: 6 mm, Länge: 53 mm
shank Ø: 6 mm, length: 53 mm

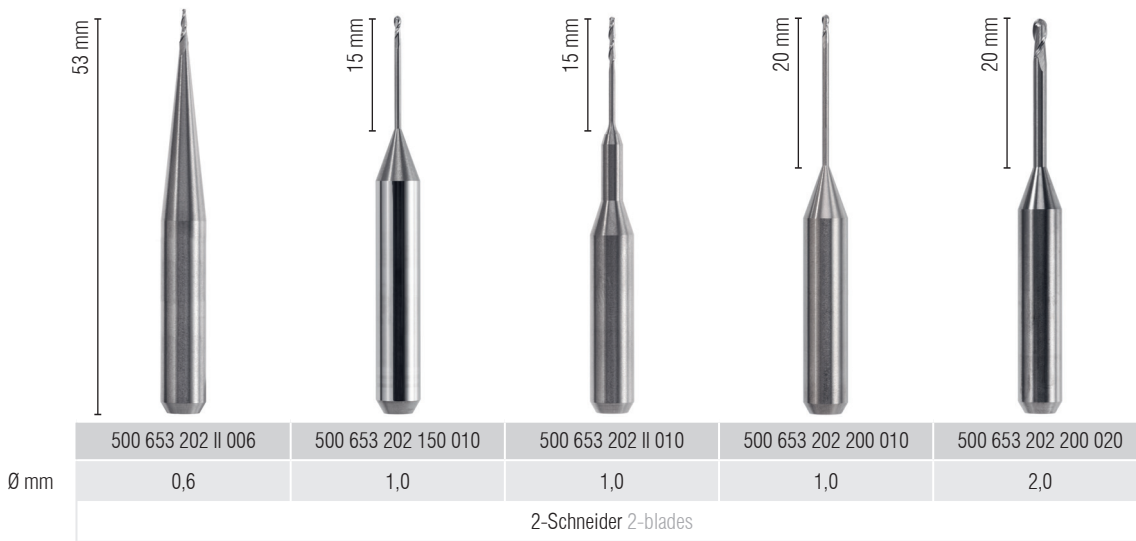

653-SERIE PMMA, WAX

Schaft Ø: 6 mm, Länge: 53 mm, Universalverzahnung
shank Ø: 6 mm, length: 53 mm, universal toothing

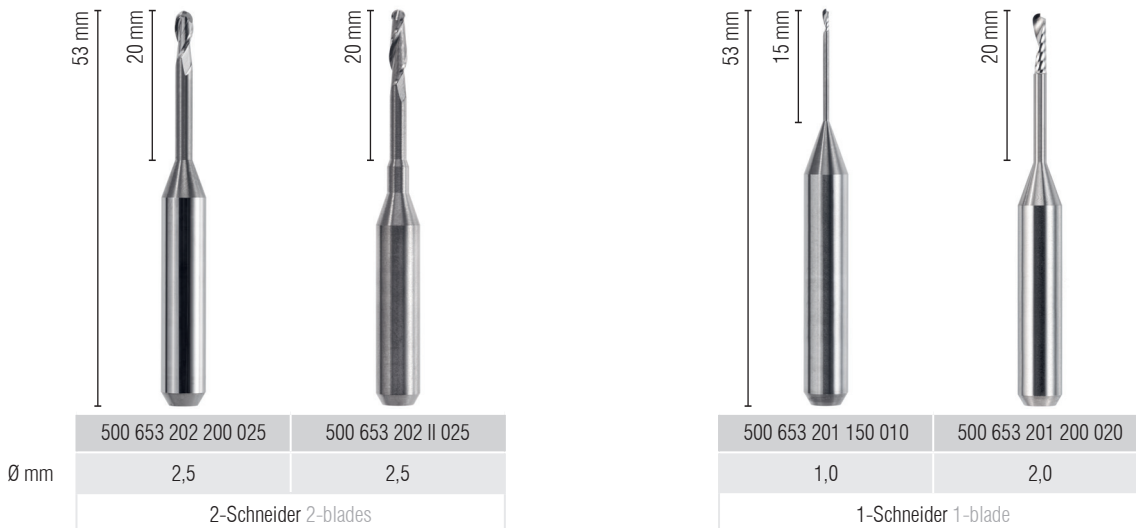





OFFENE MASCHINENSYSTEME

Ergänzungsprogramm





Open systems
Supplementary program

653-SERIE PMMA, WAX

Schaft Ø: 6 mm, Länge: 53 mm, Universalverzahnung
shank Ø: 6 mm, length: 53 mm, universal toothing

Ø mm				
	53 mm	25 mm	20 mm	15 mm
	500 653 201 250 020	500 653 201 200 025	500 653 102 150 015	500 653 104 280 040
	2,0	2,5	1,5	4,0
	1-Schneider 1-blade		2-Schneider 2-blades	4-Schneider 4-blades

ZRO (AC-KRISTALL)





Ø mm					
	53 mm	15 mm	20 mm	20 mm	20 mm
	550 653 202 150 010	550 653 202 II 010	550 653 202 200 020	550 653 202 200 025	550 653 202 II 025
	1,0	1,0	2,0	2,5	2,5
	2-Schneider 2-blades				

OFFENE MASCHINENSYSTEME

Ergänzungsprogramm





Open systems
Supplementary program

657-SERIE Schaft Ø: 6 mm, Länge: 57 mm
shank Ø: 6 mm, length: 57 mm

					
	57 mm	18 mm	20 mm	20 mm	25 mm
	16 mm				
Ø mm	1,0	1,0	1,0	2,0	2,0
	2-Schneider 2-blades				

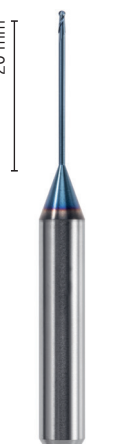
AC-BLUE

AC-KRISTALL

						
	57 mm	20 mm	20 mm	25 mm	16 mm	25 mm
	16 mm					
Ø mm	1,0	1,0	2,0	2,0	1,0	2,0
	2-Schneider 2-blades					

HARTMETALL-FISSURENBOHRER

Zum Durchtrennen der Haltestege (Grünling)
Schneidenverlauf rechts gewunden mit Querhieb/universeller Einsatz, Schaft Ø 2,35 mm

TC-fissure bur

For cutting bars (green blanks)

Twist cut to the right and cross cut for standard applications, shank Ø 2,35 mm

KONUS FLACH stirnverzahnt flat cone, front cutting

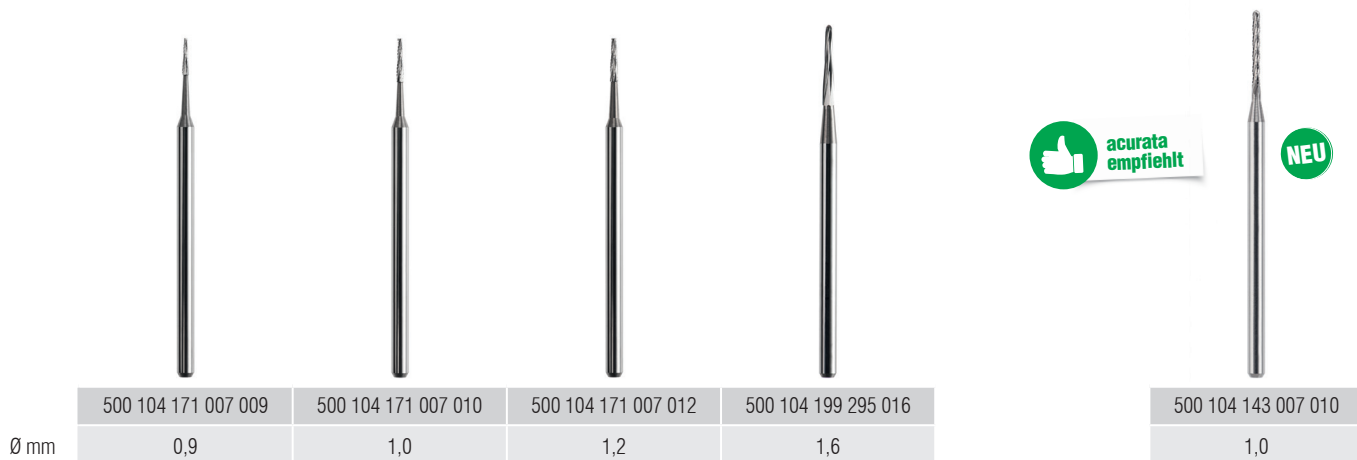

ANSCHLAG-/DISTANZRINGE

Auf Kundenwunsch können alle Werkzeuge mit Anschlag-/Distanzring versehen werden.

Stop/spacer rings

Upon customer request, all tools can be provided with stop/spacer ring.

Kunststoff plastic



030 3025

Ø mm

3,0

zusätzlich erhältlich in folgenden Farben

available in the following colours

030 3002 weiß · white

030 3003 gelb · yellow

030 3004 rot · red

030 3006 blau · blue

030 3007 grün · green

030 3008 schwarz · black

Metall metal



330 300

Ø mm

3,0



330 400

4,0



330 600

6,0

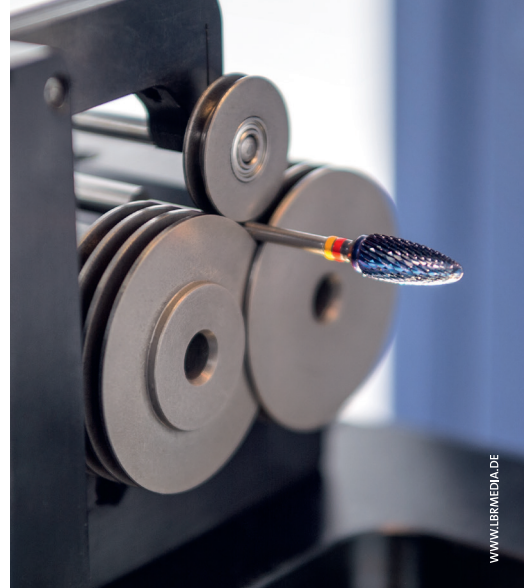

WWW.LBRMEDIA.DE

ROTIERENDE HOCHLEISTUNGSINSTRUMENTE

auf höchstem Niveau.

Zahnmediziner, Dentallabore und Podologen wertschätzen unsere praxisorientierten, bedarfsgerechten Produkte mittlerweile weltweit. Denn wir hören zu und hinterfragen. Auf einer Augenhöhe mit unseren Kunden. Auf diese Weise stellen hochkonzentrierte, leidenschaftliche Perfektionisten bei acurata absolut verlässliche Präzisionsinstrumente her, die ein ultragenaueres Arbeiten in Labor und Praxis erst ermöglichen. Zuverlässigkeit im sensiblen Zusammenwirken aller Kräfte – technisch und menschlich.

HIGH PERFORMANCE DENTAL INSTRUMENTS

to the highest technological level.

Dentists and dental laboratories now value our practically-oriented, needs-oriented products all over the world. We also listen and ask questions - at the same level as our customers. It is in this context that the highly focused, dedicated perfectionists at acurata manufacture absolutely reliable precision instruments which enable ultra-accurate work in the laboratory and in the dental practice. Reliability in the context of a sensitive collaboration between all of our talents – at the technical and human level.

WWW.ACURATA.DE



📍 acurata GmbH & Co. KG · Schulstraße 25 · 94169 Thurmsbang 📞 Telefon +49-(0) 85 04 - 91 17 0 📠 Fax +49-(0) 85 04 - 91 17 90

acurata